

**Gateway**  
Building Systems Inc.

**Seed Treating Solutions Guide**

**Choose Your Site**

Bulk Bin Site

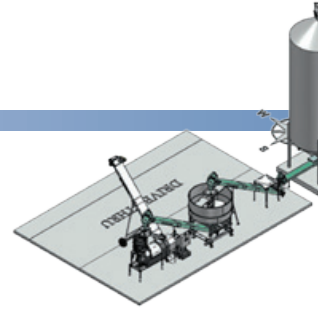

**Automation**

Fully Automated U-Treat

Simple Bin Site Automation

**Hoppers/  
Weighing  
Devices**

Continuous Flow Tri Flo

Batch Hopper

Batch Hopper

**Treaters**

LPV

LPV

Existing  
Treater

LPX  
Manual

LPX  
Automated

**Metering  
Devices**

Loss in Weight

Weight Belt

Seed Wheel

No Seed Wheel/Manu-  
al Flow

Seed Wheel

**Chemical  
Delivery  
Systems**

U-Command Rx

**Tanks**

Stainless Steel

Poly

Direct Inject

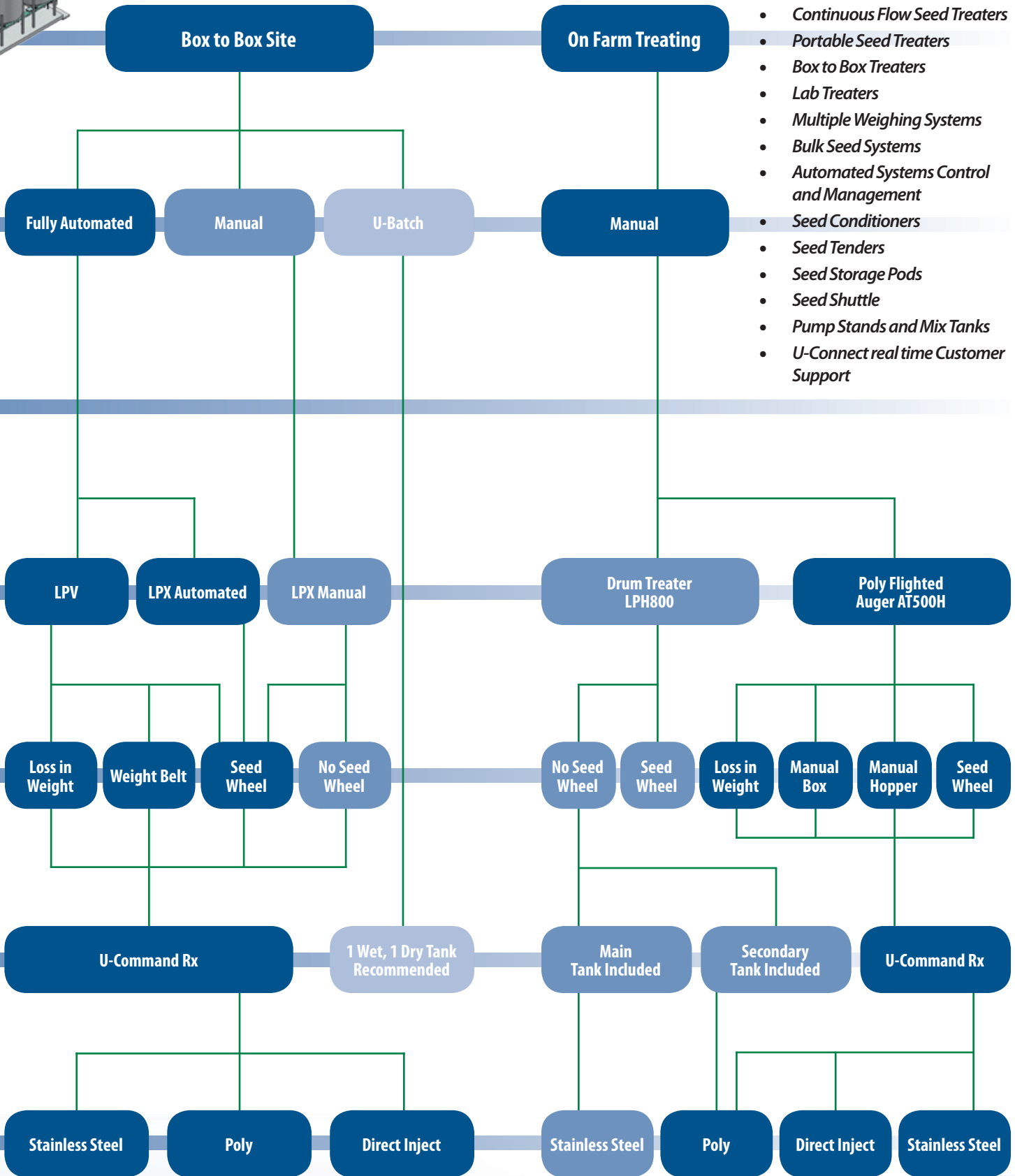

- Continuous Flow Seed Treaters
- Portable Seed Treaters
- Box to Box Treaters
- Lab Treaters
- Multiple Weighing Systems
- Bulk Seed Systems
- Automated Systems Control and Management
- Seed Conditioners
- Seed Tenders
- Seed Storage Pods
- Seed Shuttle
- Pump Stands and Mix Tanks
- U-Connect real time Customer Support

**Helping You Grow Your Business**  
For Over 60 Years



# U-TREAT AUTOMATION

## U-treat Automation

U-Treat Automation takes innovation and simplicity to the next level. Fully automated, U-Treat allows you to add additional pump stands, seed bins and other devices as your business grows. U-Treat now offers operators the ability to streamline their day to day processes with upgraded reporting, data storage and instant messenger capability. Manage up to 12 automated pump stands; create, manage

and store customized chemical recipes from a 10" Android tablet. U-Treat allows you to run and view reports on SCU and/or CWT at any time. Bin gate auto-tuning calibration closes gates quickly for better accuracy. U-Treat comes standard on automated LPX and LPV treaters, an optional upgrade is available for existing equipment.

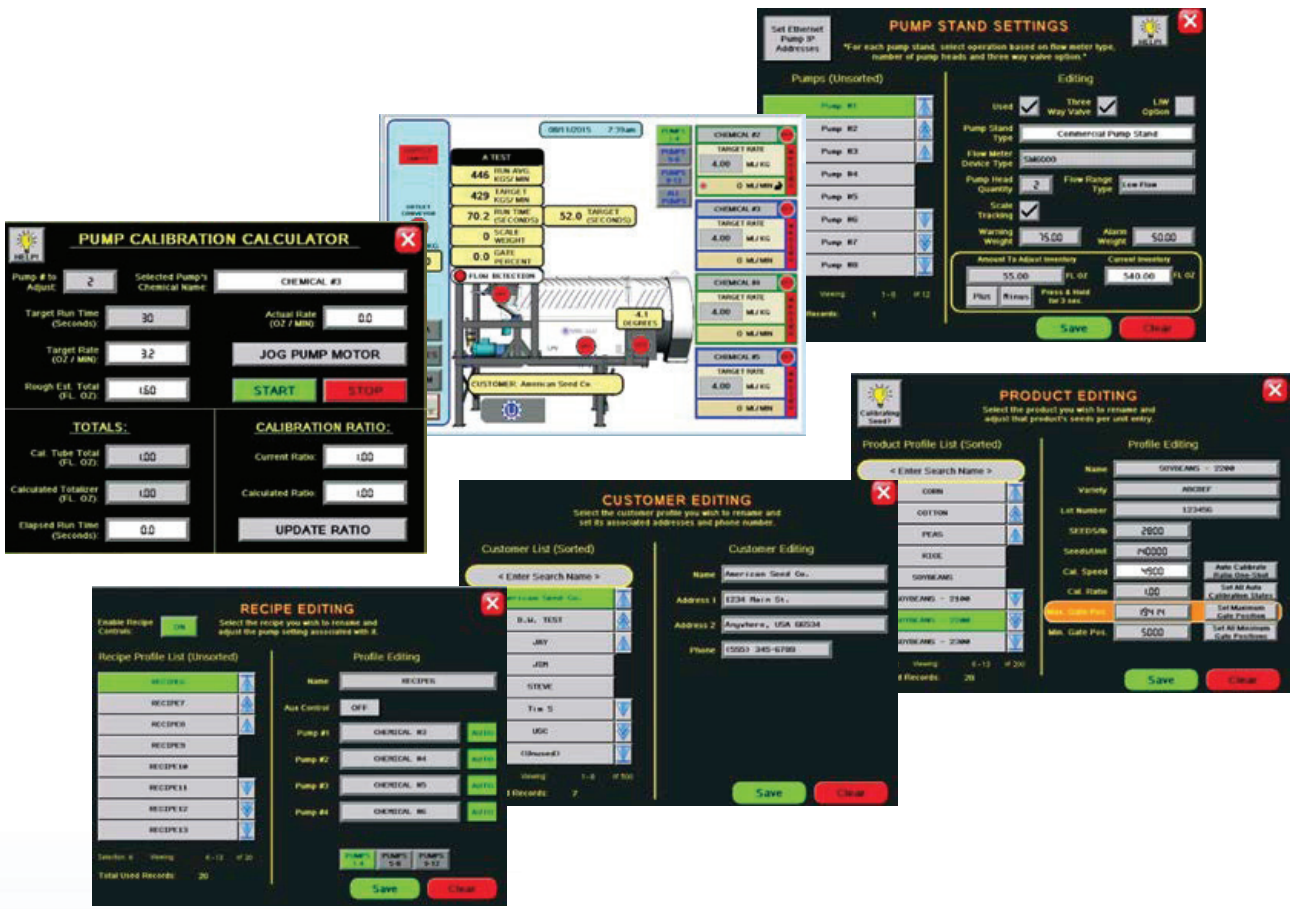

# SIMPLE BIN SITE AUTOMATION



## Simple Bin Site Automation

Known for providing affordable, innovative, reliable solutions, USC's Simple Bin Site Automation easily converts your existing seed treating equipment into a fully functioning, bulk operation with one simple automation package. Committed to bringing the latest technology and advancements in seed treating to both existing and

newly-developed operations, the USC Simple Bin Site Automation Package is the only choice to upgrade your current site with the simplest data management technology on the market. Simple Bin Site automation is a great way to test the growth potential of your operation prior to making complete expansion decisions.

- Keep your existing equipment
- Supports 2 conveyors, 1 batch hopper and up to 6 bins
- Easy conversion process
- Simple user interface for easy start up
- Includes scale indicator and ticket printer

- Provides legal scale ticket
- Include customer name on scale tickets
- Manage bin information including: seed variety, seed size, lot number and bin inventory
- Call in seed by pound or SCU

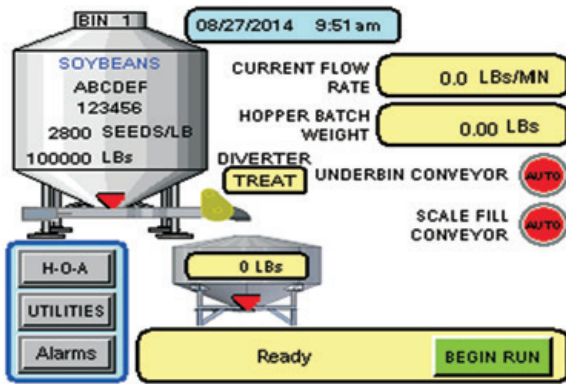

Bin Name	BIN 1	Shutdown Time	0.0 (Seconds)
Seed Type	SOYBEANS	ADJUST INVENTORY	
Seed Variety	ABCDEF	SAVE	
Lot Number	123456		
Seeds / LB	2800.0		
Seeds / Unit	140000.0		
Flow Rate	1200 Lbs/Min	24.00	Unit/Min

Helping You Grow Your Business  
For Over 60 Years



# HOPPERS/WEIGHING DEVICES

## Tri-Flo Continuous Scale

The USC Tri-Flo continuous flow scale hopper is dominating the market. The triple hopper design processes and weighs up to 1800 lbs/min with a single automated control panel capable of managing your entire bulk operation. This patented technology stands alone in the market. Cut your production time in half, manage your bin site data and customer reporting with a single compact, continuous flow design scale hopper, only by USC.



## Batch Weighing Hopper

USC Batch Weighing Hoppers are configurable from 140 - 300 units. Designed for versatility, USC hoppers can be either floor mounted or mounted directly above your treater. Each Hopper includes air gates and scale. Seed ladders are optional for the 300 unit hoppers.

## Surge Hopper

Designed for efficiency and simplicity, the USC Surge Hopper comes in multiple heights to accommodate your operation. USC Surge Hoppers are configurable from 80 – 300 units.



# METERING DEVICES



## Seed Metering Wheel

USC's Seed Metering Wheel is designed to simplify calibration and improve accuracy. A rotating wheel, driven by a variable speed motor, consists of 8 identical pockets approximately 4 inches deep. As the wheel rotates it captures precisely the same amount of seed into each pocket. The wheel constantly rotates, dispensing seed directly into the treatment chamber for a continuous flow.

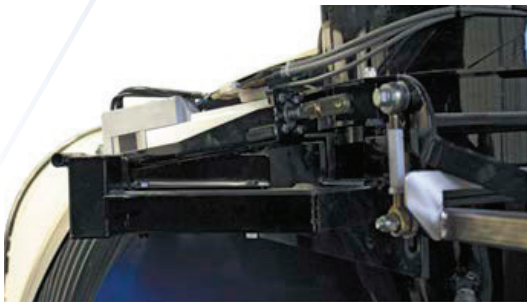

## Loss in Weight

The USC Loss in Weight system allows for versatility and accuracy in a compact design. Designed to weigh product and create a perfect symmetrical seed curtain no matter what speed you are treating at. Loss in Weight eliminates the need for in-feed conveyors, saving you time and money.

## Weigh Belt

The USC Weigh Belt solution was designed to allow for a more compact footprint in tight spaces. The weigh belt offers precise measurement of seed as it goes into the treater. The new single motor design allows for easy maintenance. Weigh belt technology is ideal for operations treating multiple seed types, including smaller seed sizes.

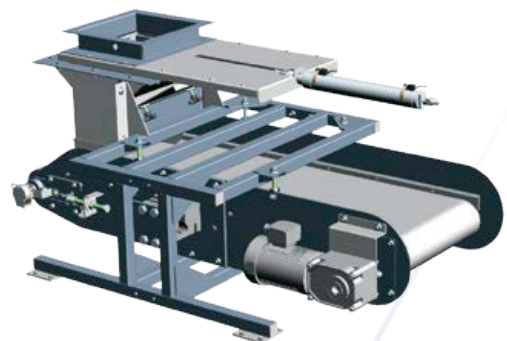

**Helping You Grow Your Business**  
For Over 60 Years



## LPV Treater

Taking customization to the next level, this treater will change the way you, and everyone in the industry, think about seed treating equipment. The LPV's revolutionary technology offers more diversified weighing and metering options. Customize your system with a Seed Metering Wheel, Loss in Weight option or a Weigh Belt. The auto-tilt drum offers a range from -5 to +2 degrees providing quick, easy cleanout. The metering device controls the flow of seed as it enters our patented atomizer chamber to guarantee a more consistent flow. This fully automated, upgradeable system will take your operation to the next level.



## U-Batch Treater

The U-Batch is the most versatile batch treating system on the market today. Capable of treating multiple types of seed, U-Batch is the perfect solution for primary treatment, overtreatment, powder application or cover crop blending. With a capacity up to 2500lbs per batch, U-Batch is designed to handle a box or super sack of seed. The simple, compact design includes our automated touch screen control panel for easy operation and storage.

## LPX2000 Treater

The LPX2000 combines the most innovative technology with the most popular seed treater on the market. The LPX2000 allows you to fully customize your treater to meet the needs of any size operation. Incorporating the same continuous flow treating benefits as our LP Series, the LPX2000 also offers the quick release atomizer chamber for easy clean up. Choose a 6', 8' or 10' carbon or stainless steel variable speed drum. Seed Wheel option available. Available in your choice of manual or automated, the LPX2000 can control multiple pump stands on a single touch screen control panel, making this is one of the simplest, most accurate treaters on the market.



# TREATERS



## LPX2000 Portable Treater

The LPX2000 Portable Treater is one of the most flexible mobile systems on the market. Designed for portability and versatility, this portable treater allows you to bring your treating system to the customer. Enjoy the benefits of USC's LPX series in a compact design. Our state of the art, single operator design accommodates multiple pump stands. Our quick release atomizer chamber makes clean up a snap. Just like our larger stationary treaters, our portable design offers a variable speed drum and configurable peristaltic pump for easy calibration and precision accuracy.



## LPH800 Treater

The LPH series treating unit, with its simple design, allows for easy calibration of both seed and chemical flows. The LPH800 is a continuous flow system with a 13" atomizer and 6' drum. Perfect for smaller operations, the LPH800 arrives ready to operate with a stainless steel mix tank, poly tank, peristaltic pumping system, control panel and a quick release slide out atomizer chamber for easy clean up. Add a seed wheel to this treater to simplify calibration and improve accuracy.

## AT500H Treater

The AT500H was designed for convenience, flexibility and simplicity. Featuring our innovative quick release clean atomizer chamber, the AT500H is a continuous flow treating system with a variety of metering options to accommodate your needs. Options include Manual Adjustable Chamber, Loss in Weight and Seed Wheel.



**Helping You Grow Your Business**  
For Over 60 Years



## DESIGNED TO MOVE SEED WITHOUT DAMAGE

### TS Conveyors

- Eliminates spillage and reduces friction to increase belt life.
- Lengths from 12' to 45'.
- Galvanized steel construction.
- Designed to fit anywhere with a built-in hitch for easy portability.



### Bin Fill Conveyors

- Lengths from 55' to 70'.
- Collapsible hopper standard
- 2" high cleats spaced on 7".
- 10" discharge spout.
- Either hydraulic or electric over hydraulic lifts.



### Truck Unload Conveyor

- Designed for simplicity and convenience.
- Adjustable height incline for convenient truck unload.
- 5HP motor and flexible rubber discharge are standard.



### Dry Additive Feeder

The USC Dry Additive Feeder can be used to apply talc, micro nutrients, dry inoculants or other additives with precision accuracy. The USC DAF is compatible with most treaters on the market today. Designed for simplicity and flexibility the DAF's mild steel base can rotate 360° on it's provided adjustable stand. Comes standard with automated touch screen panel, hopper and on/off display timers. The DAF allows you to program multiple unique recipes including product weight, treater run ratio, unit of measure, product density, calibration ratio and individual recipe name. Eliminate unnecessary waste, saving you both time and money by customizing your recipe for more accurate, efficient control no matter what your application.

### Seed Conditioner

USC's Seed Conditioner uses a combination of speed and ambient air to reduce surface moisture and increase seed quality gently and efficiently. Reduce the need for double dumping treated seed, decrease bridging and clumping and tie directly to your USC treater. Capable of conditioning over 1800 lbs/minute the USC Seed Conditioner is a great asset for high volume seed treating facilities. The ability to dump treated seed right into your truck or tender saves both time and money.



# CHEMICAL DELIVERY



## What is U-Command Rx®

U-Command Rx is the most innovative, fully automated system available for controlling chemical application rates with precision accuracy. U-Command Rx gives you the freedom to create and store custom-blended prescriptions and manage your entire seed treating system from a single control panel. One operator with one Android tablet can manage your entire operation. This system is compatible with both automated and semi-automated chemical delivery systems. Reduce chemical waste and minimize chemical handling by utilizing a closed loop static mixing process that allows you to pull directly from your chemical containers and delay the mixing process until chemical is ready to enter the atomizer chamber. U-Command Rx

can be tailored to fit your application by simultaneously controlling multiple pump stands. This process alleviates the cost and inconvenience of unnecessary mix tanks and possible contamination when changing recipes between customers. Import and export data including customer information, chemical profiles, seed profiles, bin information and job reports. Email capability allows users to send reports after each batch or overall reports for multiple batches customized to fit your needs. The U-Command Rx system is backed and serviced by UConnect, USC's premier remote access program featuring program updates, real-time troubleshooting and online support from certified USC service technicians.

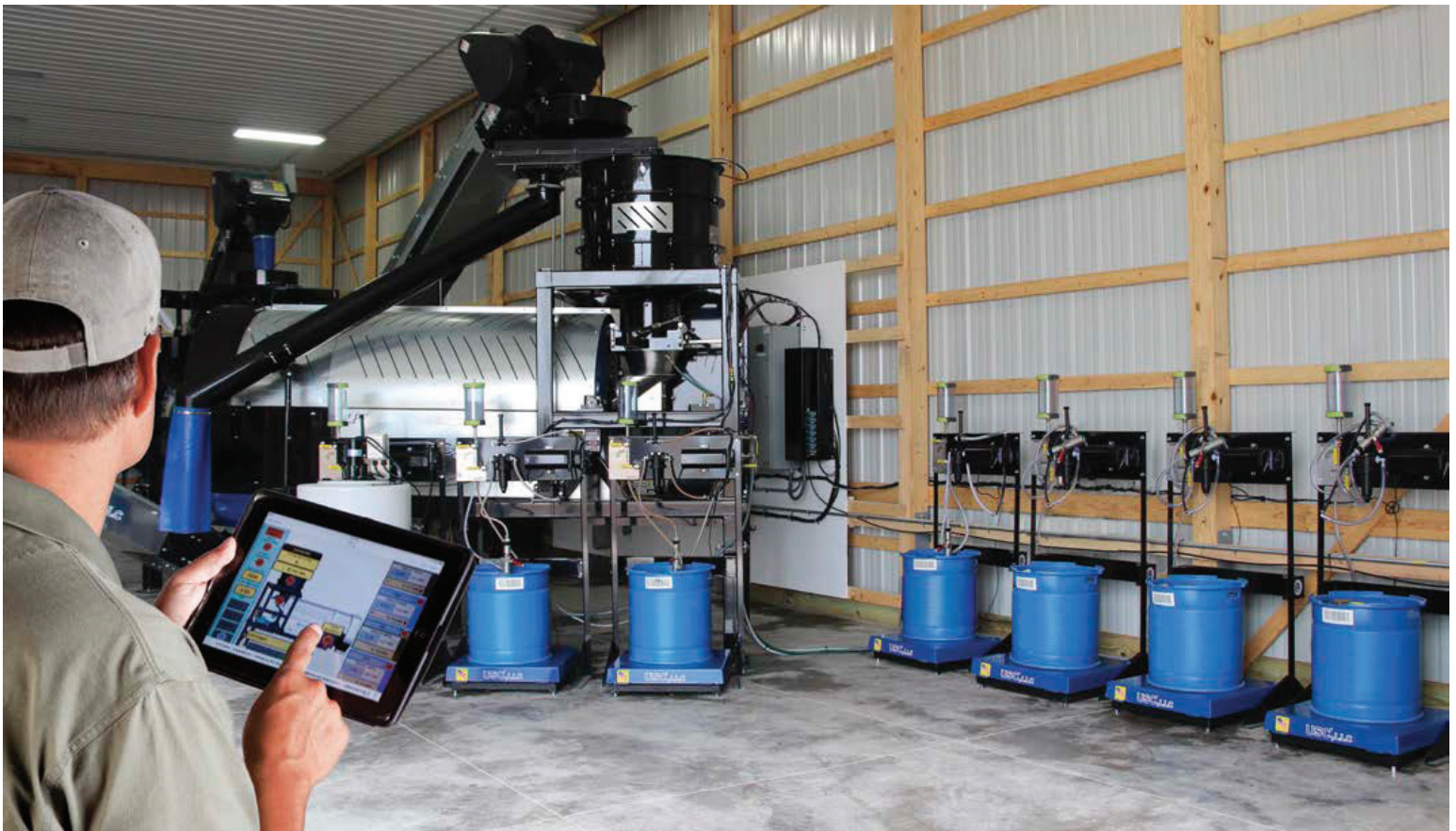

# U-COMMAND RX

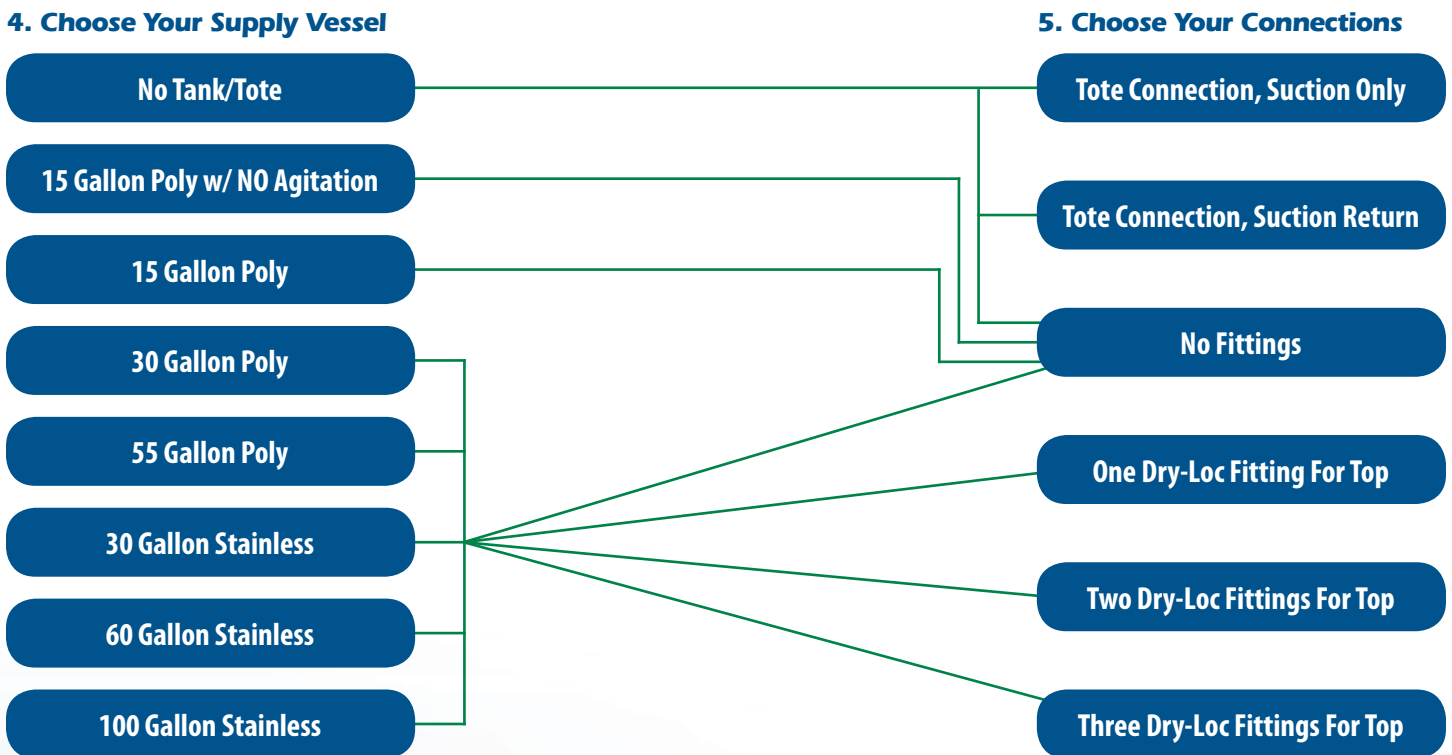
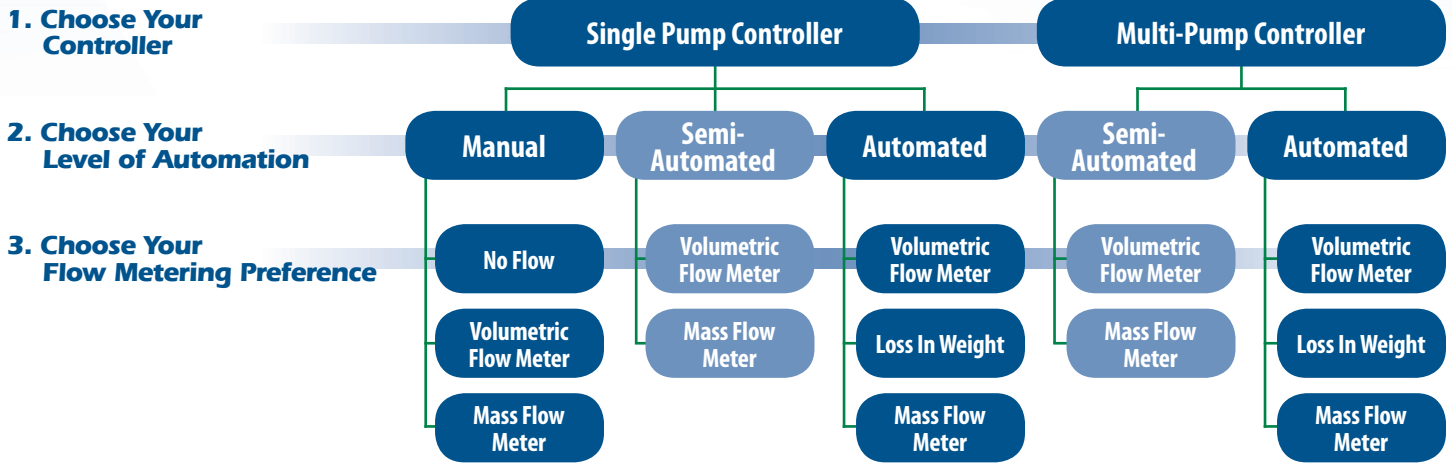

# U-COMMAND RX



## 6. Choose Your Flow Range

2-10 fl oz/min

5-65 fl oz/min

10-135 fl oz/min

15-225 fl oz/min

20-350 fl oz/min

## 8. Choose Your Calibration Method

No Calibration Tube

Calibration Tube

## 9. Choose Your Scale

No Scale

Scale w/ Read Only Indicator

## 7. Choose Your Mounting

Floor Mount

Box Mount

## 10. Choose Your Recirculation/Process Valve

Single Controller

Multiple Controller

Automated

Air Recirculation/  
Process Valve

Manual Recirculation/  
Process Valve



Manual Pump Stands and Mix Tanks



Automated Pump Stands and Mix Tanks



Semi-Automated Mix Tanks

Helping You Grow Your Business  
For Over 60 Years





## UltiMaxx900

The ultimate seed transport solution. UltiMaxx900 offers 1125 cubic feet of storage capacity, a 20' discharge conveyor with 180° swing load out conveyor. This system is remote control operated for precision placement and offers either a three 300-unit hopper design or six 150-unit hopper design. Comes standard with a rollover tarp, automatic tarp optional.

## FLXTOR® Seed Pods

FLXTOR Seed Pods alleviate the need for boxes or bags, designed for easy transport and sealed for weatherproof storage anywhere. With either the 350-unit portable pod that fits perfectly with the USC Seed Shuttle or the 400-unit stationary pod, FLXTOR has the perfect solution for year round seed delivery and storage.



## FLXTOR® Transformer

The FLXTOR Transformer allows you the freedom to deliver seed to any location, anytime. The hydraulic conveyor offers a 180° swing for greater flexibility. Comes standard with a self-contained generator and remote controls for the conveyors.

## FLXTOR® Seed Shuttle

FLXTOR Seed Shuttle is designed to work with the FLXTOR Seed Pods. The Shuttle allows you direct deliver full pods to any customer.



## Preventative Maintenance

Count on your equipment, when so many count on you... Gateway Building Systems has nationwide Preventative Maintenance options. Performed by trained technicians, a P.M. can extend the life of your equipment, save you money, and prevent breakdowns during the busy seed season.

## Preventative Maintenance Options

### Treater P.M.

- Includes complete inspection of Sensors, Relays, Timers, Switches, Potentiometers, Controls, Chains, Bearings, Valves, Hoses, Filters, Pumps, Atomizer, SeedWheel, Flowmeter, and Mix Tank.
- Oil & Greasing.

### Portable Treater P.M.

- Includes all inspection categories under Treater P.M.
- Also includes Inlet and Outlet Conveyors, and Generator.
- Oil & Greasing.

### Complete Bulk Site P.M.

- Includes all inspection categories under Treater P.M.
- Also includes Inspection of all Bulk Site conveyors, belt alignment, and bin gates.
- Oil & Greasing.

Treater Only .....	\$449
Portable Treater .....	\$595
Complete Bulk Site .....	\$795
Service Rate .....	\$95/hr.



- Seed Treater must be drained and rinsed of chemical prior to P.M.
- Necessary repairs and part replacement will be an additional charge with customer approval.

**West Fargo**  
2138 Main Ave W  
West Fargo, ND 58078  
701.293.7202

**Jamestown**  
2505 17th Street SE  
Jamestown, ND 58501  
701.952.9300

**Fergus Falls**  
17153 Co. HWY 82  
Fergus Falls, MN 56537  
218.998.2994



# Gateway

## Building Systems Inc.

When it comes to treating, handling, building,  
and storage solutions, one call does it all.



**701-293-7202**

[seedtreatment@gatewaybuilding.com](mailto:seedtreatment@gatewaybuilding.com)

[gatewaybuilding.com](http://gatewaybuilding.com)